

## CV-14L/DC lock release

Reference: CV-14L/DC  
 Product code: 20620149  
 EAN code: 8429898016214



### Main characteristics

- **Standard operation**, which only enables the door to be opened while the lock release push button of the apartment unit is pressed.
- **Medium size shield**.
- Casing manufactured in 2mm. thick pressure injected light alloy, with a height of 90mm.
- Adjustable bolt on all models, allowing 3 mm. precision.
- Operation voltage from 8 to **12V c.c.** (750mA consumption).

### Additional information

- Dimensions:

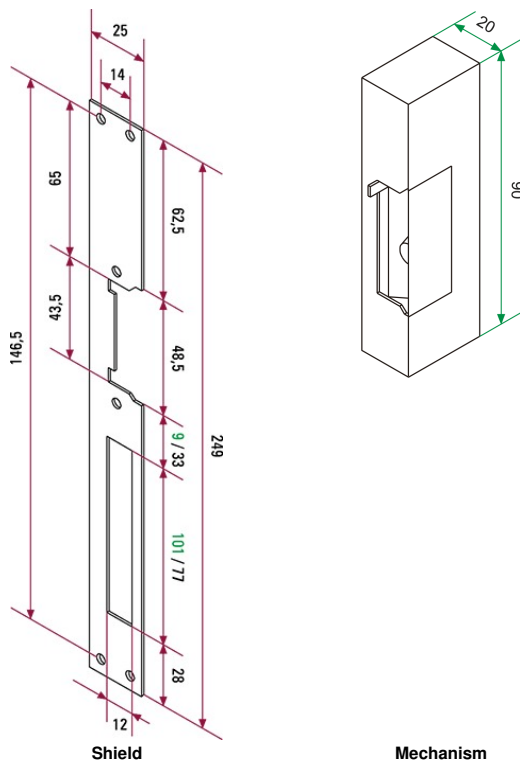

Visit in the website: <https://www.golmar.es/products/cv-14l-dc-lock-release>

---

**Golmar Sistemas de Comunicación S.A.**

Silici 13 · 08940 Cornellà de Llobregat (Barcelona) · Tel: +34 934 800 696 · Fax: +34 934 742 404 · [golmar@golmar.es](mailto:golmar@golmar.es) · [www.golmar.es](http://www.golmar.es)