

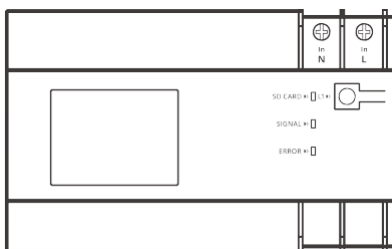

# DIY SPM

User manual V1.0



SPM-Main

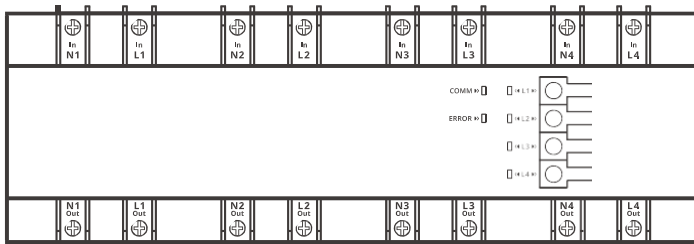

SPM-4Relay

## SONOFF Smart Stackable Power Meter (Main Unit+4-Relays)

# Product Introduction

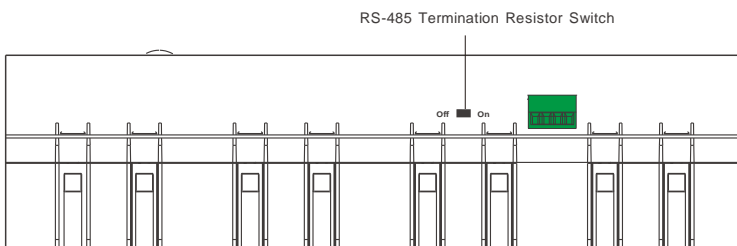
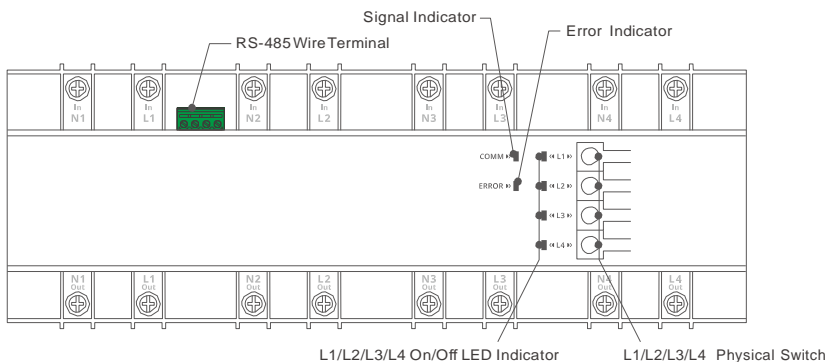
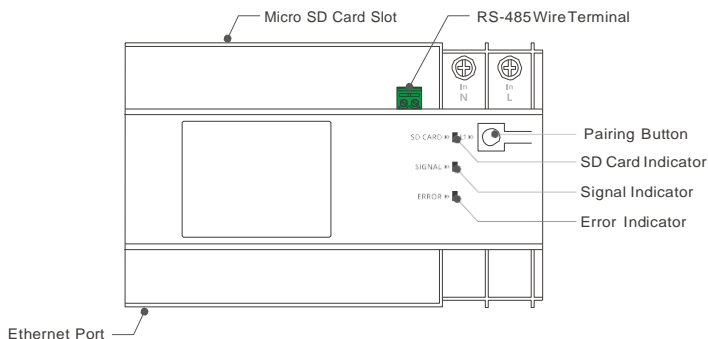

⚠ The device weight is less than 1 kg; the installation height of less than 2 m is recommended.

## Features

SPM-Main and SPM-4Relay are the main unit and slave unit of SONOFF Smart Stackable Power Meter, and both are designed to work together. You can control the added slave unit in the App through pairing the main unit with the eWeLink App.

### SPM-Main:



### SPM-4Relay:



⚠ SPM-Main supported Micro SD card sizes: 8GB - 32GB.

⚠ Find Me: Select the sub-device and press the “Find Me” icon on the eWeLink App, then the corresponding slave's error indicator of this sub-device will flash for 20s.

## Operating Instruction

### 1. Power off

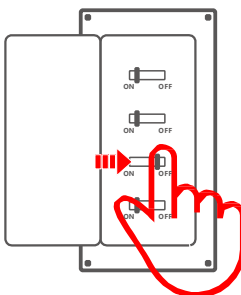

⚠ Please install and maintain the device by a professional electrician. To avoid electric shock hazard, do not operate any connection or contact the terminal connector while the device is powered on !

## 2. Wiring Instruction

### Wiring Instruction of SPM-Main & SPM-4Relay and SPM-4Relay & the Slave Unit:

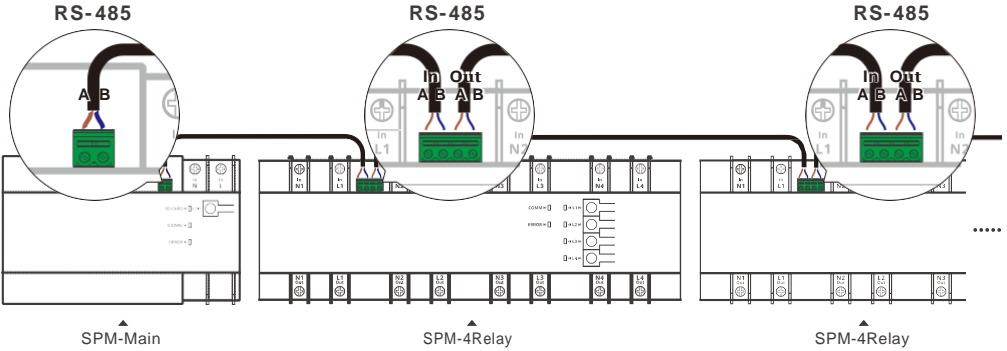

- ⚠ The main unit can be added up to 32 slave units (The length of RS-485 bus shall be less than 100m).
- ⚠ The wire connected to the main unit and slave unit must be 2-core RVVSP cable with single wire diameter of  $0.2\text{mm}^2$ .
- ⚠ To ensure the reliable communication of the RS-485 bus, please keep one end of the shielded layer connecting to the ground wire and the other end hanging in the air.

### Light Fixture Wiring Instruction:

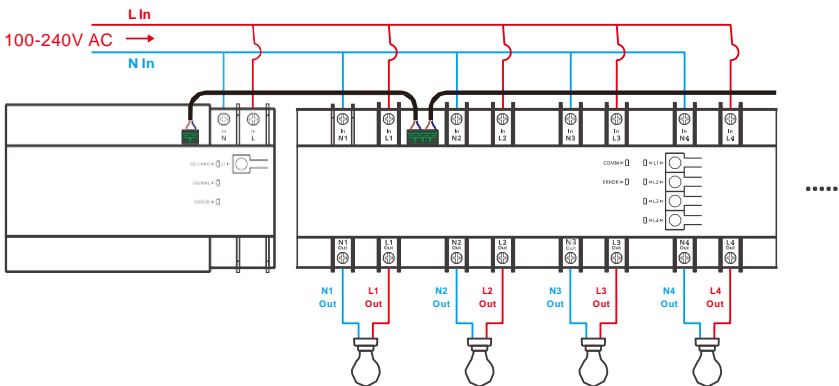

- ⚠ There are 4 channels in SPM-4Relay, the first channel is designed to power the device so that it has to be powered on; Each channel is independent, only the input end is powered on can the corresponding output end of the channel work successfully.
- ⚠ Ensure the proper wiring before powering the units on.

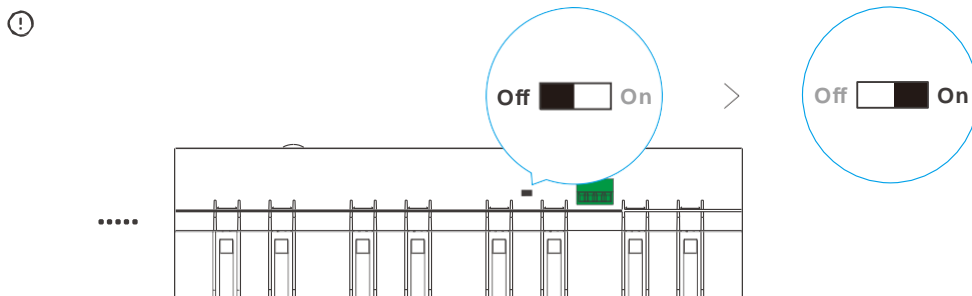

The "RS-485 Termination Resistor Switch" of the slave unit is off by default. To make sure stable communication, the "RS-485 Termination Resistor Switch" of the terminal slave unit shall be turned on.

### 3. Download the eWeLink App



### 4. Power on

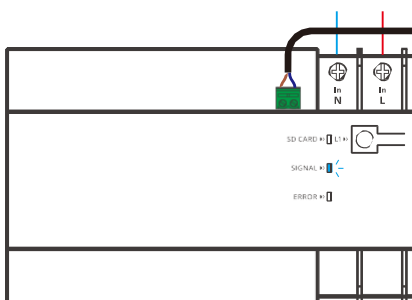

After powering on, the device will enter the Bluetooth Pairing Mode during the first use. The Signal Indicator flashes quickly.

⚠ The device will exit the Bluetooth Pairing Mode if not paired within 3mins. If you want to enter this mode again, please long press the pairing button for about 5s until the Signal Indicator flashes quickly and release.

## 5. Add Device



Tap “+” and select “Bluetooth Pairing”, then operate following the prompt on the App.

## 6. Add the Slave Unit to the Main Unit

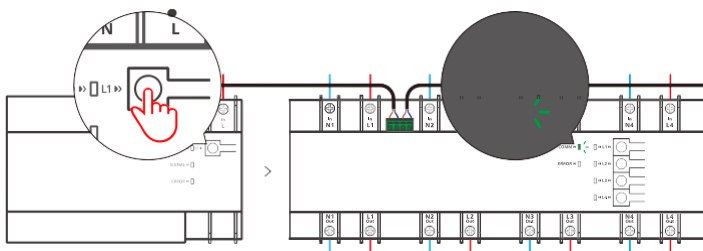

Press the Pairing Button on the main unit once to enable it enter the scan status, then the COMM Indicator of the slave unit “flashes slowly”. The slave unit will appear in the list of main unit interface on the eWeLink App as a sub-device after being added to the main unit.

- ⚠ The slave unit has not been scanned successfully within 20s, the main unit will exit the scan status. If you want to scan the slave unit again, you can press the Pairing Button on the main unit once again.
- ⚠ The connected slave unit can be added and controlled by powering on the main unit again.

## Insert Micro SD Card (SPM-Main)

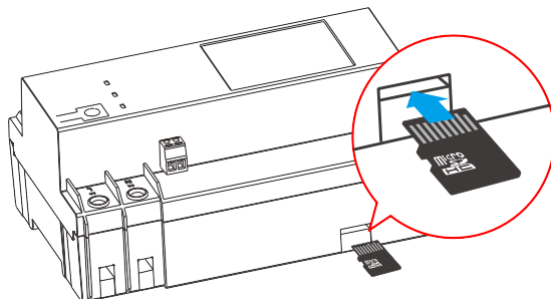

⚠ Make sure Micro SD Card is inserted correctly (Micro SD Card is sold separately).

## Specifications

### SPM-Main

Model	SPM-Main
Input	100-240V ~ 50/60Hz 50mA Max
Wi-Fi	IEEE 802.11 b/g/n 2.4GHz
Working Temperature	-10°C ~ +40°C
App Operating Systems	Android & iOS
Shell Material	PCV0
Dimension	142.5x90x66.5mm

### SPM-4Relay

Model	SPM-4Relay
Input	100-240V ~ 50/60Hz 20A/Gang 80A/Total Max
Output	100-240V ~ 50/60Hz 20A/Gang 80A/Total Max
Working Temperature	-10°C ~ +40°C
Shell Material	PCV0
Dimension	250x90x66.5mm

## Instruction of the SPM-Main Indicator Status

### SD Card Indicator (Green)

Indicator Status	Status Instruction
Flashes Once	Reading SD Card or Flashing

### Signal Indicator (Blue)

Indicator Status	Status Instruction
Flashes Quickly	Bluetooth Pairing Mode
Keep On	Device is Online
Flashes Quickly Once	Fail to Connect to Router
Flashes Quickly Twice	Connected to Router but Fail to Connect to Server
Flashes Quickly Thrice	Firmware Updating

### Error Indicator (Orange)

Indicator Status	Status Instruction
Flashes (Appr. 20s)	The Main Unit is Scanning the Slave Unit
Keep On	Chip Error
Keep Off	Fault-free

## Instruction of the SPM-4 Relay Indicator Status

### COMM Indicator (Green)

Indicator Status	Status Instruction
Flashing (Appr. 20s)	The Main Unit is Scanning the Slave Unit
Flashes Once Periodicity in 2-5s	Normal Communication

### Error Indicator (Orange)

Indicator Status	Status Instruction
Flashing (Appr. 20s)	Active the "Find Me" feature in the App
Keep On	Power Monitoring error, Temperature, Current or Voltage Exceeds the Threshold Value
Keep Off	Fault-free

### L1/L2/L3/L4 On/Off LED Indicator (Red)

Indicator Status	Status Instruction
LED On	On
LED Off	Off

## SPM-Main Ethernet Usage

Only the main unit was paired successfully in the eWeLink App can it be connected to Ethernet to work.

ⓘ After connecting to Ethernet, the main unit will use Ethernet in preference (Wi-Fi and Ethernet can be the different network).

## SPM-Main Re-establish Pairing

The main unit need to be paired again when you replace its account or connected Wi-Fi. Long-press the pairing button for 5s until the Signal Indicator flashed quickly and release. Now the device had entered Bluetooth Pairing Mode, you can add the devices in the App through Bluetooth Pairing again.

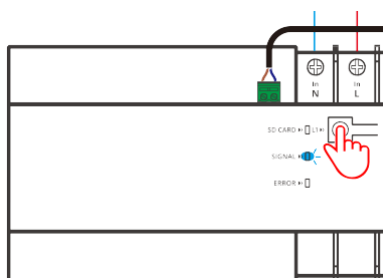

## Factory Reset

Deleting the device on the eWeLink App indicates you restore it to factory setting.

## RS-485 Bus Installation Cautions

Cable Selection:

Using 2-core RVVSP cable, copper wire core  $\geq 0.2\text{mm}^2$ .

Wiring Recommendation:

1. The length of the cable bus shall be less than 100m.
2. Using the same type of cable in one cable bus system.
3. Reduce the connectors in the line. Ensure the solid connection and seal to avoid loosening and oxidation.
4. Daisy-chain connection rather than Star connection and Branch connection.
5. RS-485 bus's one end of the shielded layer shall be connected to the ground wire.
6. During the installation, please turn on the RS-485 Termination Resistor Switch while other units are kept off.

## Common Problems

### Fail to pair Wi-Fi devices with eWeLink APP

1. Make sure the device is in pairing mode.

The device will automatically exit the pairing mode if not paired within 3mins.

2. Please turn on the location service on your mobile phone and give the permission.

Before choosing the Wi-Fi network, the location service should be turned on and the permission is given. Location information permission is used to obtain Wi-Fi list information. If you tap "Disable", the device will not be added.

3. Make sure your Wi-Fi network runs on the 2.4GHz band.

4. Make sure you entered a correct Wi-Fi SSID and password, no special characters contained.

A wrong password is a very common reason for pairing failure.

5. You may get the device close to the router for a good signal transmission while pairing.

### Wi-Fi devices "Offline" issues

Please check the following issues by the Wi-Fi LED indicator status:

The LED indicator blinks once every 2s means you fail to connect to the router.

1. Maybe you entered a wrong Wi-Fi SSID and password.

2. Make sure your Wi-Fi SSID and password don't contain special characters, for example, the Hebrew, Arabic characters. Our system can't recognize these characters so that fail to connect to the Wi-Fi.

3. Maybe your router has a lower carrying capacity.

4. Maybe the Wi-Fi signal strength is weak. Your router is too far away from your device, or there may be some obstacles between the router and the device so that the signal transmission is blocked.

5. Be sure that the MAC of the device is not on the blacklist of your MAC management.

### The LED indicator flashes twice on repeated means you fail to connect to the server.

1. Make sure the Internet connection is normal. You can use your phone or PC to connect to the Internet, and if you fail to access, please check the availability of the Internet connection.

2. Maybe your router has a low carrying capacity. The number of devices connected to the router exceeds its maximum value. Please check the maximum number of devices that your router can carry. If the number of connected devices exceeds the maximum value, please delete some devices or change a larger router and try again.

3. Please contact your ISP and confirm our server address is not shielded:

cn-disp.coolkit.cc (China Mainland)

as-disp.coolkit.cc (in Asia except China)

eu-disp.coolkit.cc (in EU)

us-disp.coolkit.cc (in US)

If none of the above methods solved this problem, please submit your issue via help & feedback on the eWeLink App.

## FCC Warning

Changes or modifications not expressly approved by the party responsible for compliance could avoid the user's authority to operate the equipment.

This device complies with part 15 of the FCC Rules. Operation is subject to the following two conditions: (1) This device may not cause harmful interference, and (2) this device must accept any interference received, including interference that may cause undesired operation.

### **FCC Radiation Exposure Statement:**

This equipment complies with FCC radiation exposure limits set forth for an uncontrolled environment. This equipment should be installed and operated with minimum distance 20cm between the radiator & your body. This transmitter must not be co-located or operating in conjunction with any other antenna or transmitter.

### **Note:**

This equipment has been tested and found to comply with the limits for a Class B digital device, pursuant to part 15 of the FCC Rules. These limits are designed to provide reasonable protection against harmful interference in a residential installation. This equipment generates, uses and can radiate radio frequency energy and, if not installed and used in accordance with the instructions, may cause harmful interference to radio communications. However, there is no guarantee that interference will not occur in a particular installation. If this equipment does cause harmful interference to radio or television reception, which can be determined by turning the equipment off and on, the user is encouraged to try to correct the interference by one or more of the following measures:

- Reorient or relocate the receiving antenna.
- Increase the separation between the equipment and receiver.
- Connect the equipment into an outlet on a circuit different from that to which the receiver is connected.
- Consult the dealer or an experienced radio/TV technician for help.

Hereby, Shenzhen Sonoff Technologies Co., Ltd. declares that the radio equipment type SPM-Main, SPM-4Relay is in compliance with Directive 2014/53/EU. The full text of the EU declaration of conformity is available at the following internet address:

<https://sonoff.tech/usermanuals>



**Shenzhen Sonoff Technologies Co., Ltd.**

1001, BLDG8, Lianhua Industrial Park, shenzhen, GD, China  
ZIP code: 518000 Website: sonoff.tech

MADE IN CHINA

